

1 Insert handle from right side and attach handle onto master shaft. Then insert knob set and tighten the handle.

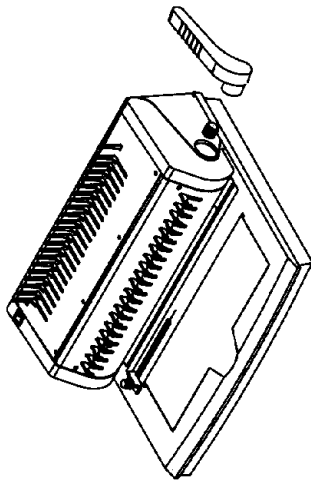

3 1. Adjust side guide.
2. Pull set pin out to cancel this die if you find edge of document partially covers one of white rectangles on the alignment scale.
3. Adjust knob for binding depth to 1.2, 3, or 4.

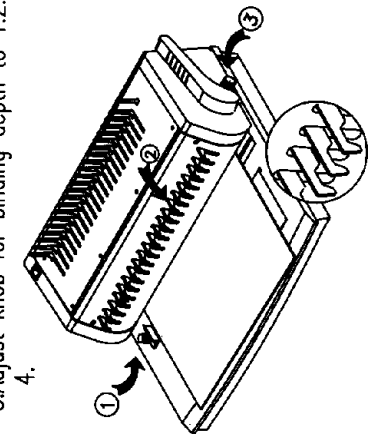

5 Place ring with opening side up behind metal finger.

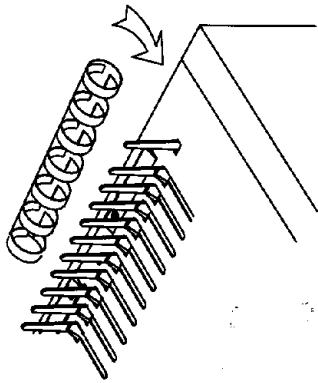

7 Insert papers vertically and make sure all fingers are line up with punched holes lay down papers horizontally. Continue this step until all papers are bound.

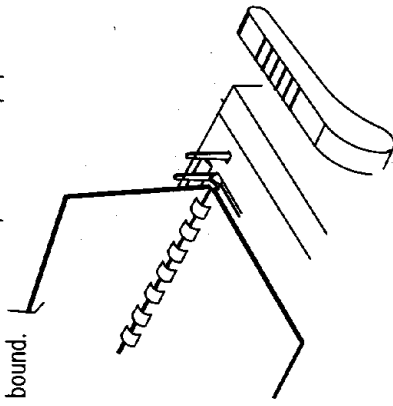

2 Measure the thickness of papers to be bound and determine punching depth by using binding gauge. Select correct diameter of binding comb to use.

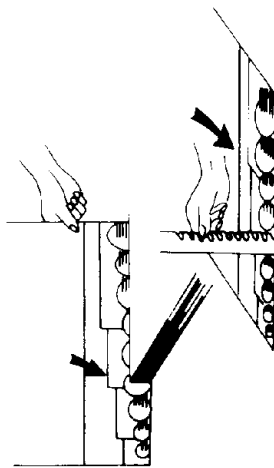

4 Insert paper into punch throat. Push the punch switch on the left hand on the top cover to punch. Continue this step until all papers are punched.

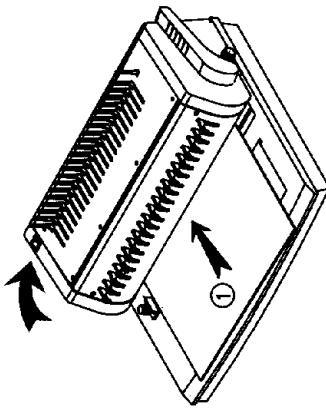

6 1. Push the Master Arm backward until the opening of binding is reached what you wanted.
2. Hold it there.

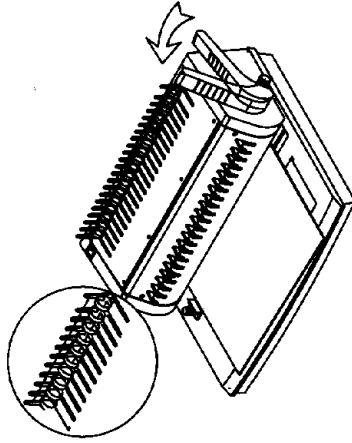

8 Return handle to upright. remove book from metal fingers. And you have a professionally bounded document.

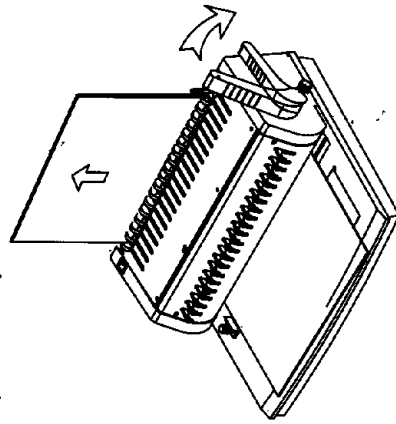

DEPTH 4

DEPTH 3

DEPTH 2

DEPTH 1

BINDING GAUGE & DIAMETER GUIDE

